

G280F Fire Safe API607 Two Piece Full Port Ball Valve

- Size Range 1/4" - 4" (DN08 - DN100)
- Pressure Rating 2000 PSI (1/4"-2")
1500 PSI (2 1/2"-4")
- Materials Stainless Steel, Carbon Steel
- End Connection Threaded
- Service Application Water, Oil, Gas, Thermal Fluid,
Chemicals and others
- Certifications ISO 9001, PED 97/23/EC
- Operation Manual or Actuated

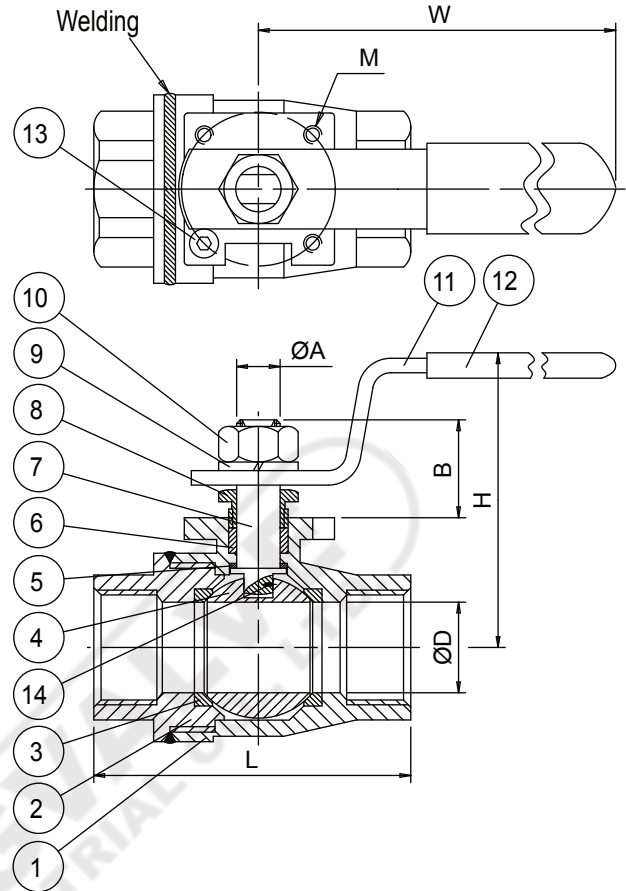

MATERIAL LIST:

ITEM	DESCRIPTION	STAINLESS STEEL	CARBON STEEL	Q'TY
1	BODY	ASTM A351 CF8M	ASTM A216 WCB	1
2	BODY CAP	ASTM A351 CF8M	ASTM A216 WCB	1
3	SEAT	PTFE	PTFE	2
4	BALL	ASTM A351 CF8M/316	ASTM A351 CF8/304	1
5-1	THRUST WASHER	PTFE	PTFE	1
5-2	THRUST WASHER	GRAPHITE	GRAPHITE	1
6	STEM PACKING	GRAPHITE	GRAPHITE	1
7	STEM	ASTM A276 316	ASTM A276 304	1
8	GLAND	PTFE	PTFE	1
9	SPRING WASHER	AISI 304	AISI 304	1
10	HANDLE NUT	AISI 304	AISI 304	1
11	HANDLE	AISI 304	ZINC PLATED STEEL	1
12	SLEEVE	VINYL PLASTISOL	VINYL PLASTISOL	1
13	STOP PIN	AISI 304	CARBON STEEL	1
14	ANTI-STATIC DEVICE	AISI 304	AISI 304	1

P-T RATINGS

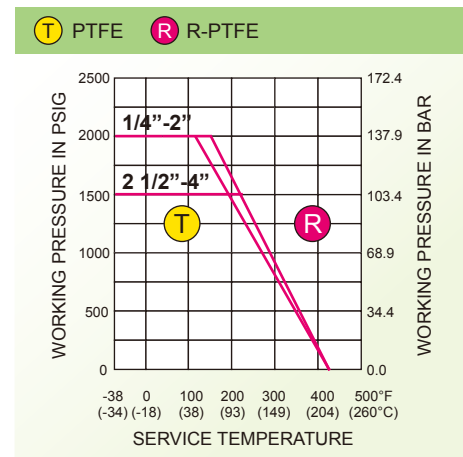

DIMENSIONS:

SIZE		ØD		L		H		W		A		B		M	ISO 5211	Weights KG
IN	DN	IN	MM	IN	MM	IN	MM	IN	MM	IN	MM	IN	MM			
1/4"	8	0.43	11.0	2.32	59	2.13	54	5.31	135	0.31	8	0.59	15	M5	F03	0.4
3/8"	10	0.49	12.5	2.32	59	2.13	54	5.31	135	0.31	8	0.59	15	M5	F03	0.4
1/2"	15	0.59	15.0	2.40	61	2.20	56	5.31	135	0.31	8	0.67	17	M5	F03	0.4
3/4"	20	0.79	20.0	2.87	73	2.52	64	5.31	135	0.39	10	0.79	20	M5	F03	0.6
1"	25	1.00	25.4	3.35	85	2.68	68	6.50	165	0.47	12	0.98	25	M5	F04	1.0
1 1/4"	32	1.26	32.0	3.82	97	2.91	74	6.50	165	0.47	12	0.98	25	M5	F04	1.5
1 1/2"	40	1.50	38.0	4.53	115	3.54	90	6.89	175	0.55	14	0.98	25	M6	F05	2.2
2"	50	1.97	50.0	5.28	134	3.94	100	6.89	175	0.55	14	0.98	25	M6	F05	3.8
2 1/2"	65	2.56	65.0	6.61	168	5.39	137	10.24	260	0.79	20	1.57	40	M8	F07	6.5
3"	80	3.15	80.0	7.52	191	5.79	147	10.24	260	0.79	20	1.57	40	M8	F07	11.8
4"	100	3.94	100.0	9.09	231	6.93	176	11.02	280	0.98	25	1.57	40	M10	F10	20.3